

Package

Plate Heat Exchanger By 

A Perfect Fit for Fast Heat Exchange



Package Plate Heat Exchanger

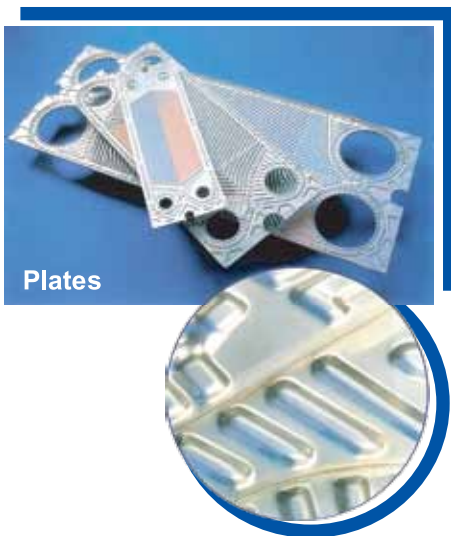

Plates

ITC's Package Plate Heat Exchanger is a perfect fit for fast heat exchange because of its large surface area and the compact plate's alignment. As a result, speedy heat transfer happens.

During the heat exchange, only two substances involve: ammonia and water with glycol (antifreeze substance). Both substances will flow through each plate and transfer the heat. Consequently, operating on -5°C evaporating temperature and water a 3°C inlet temperature will yield a -2°C outlet temperature. Furthermore, due to the high tensile strength of SS304 material stainless steel, the plate sheet can last for a longer time. The maximum working pressure of the refrigerant side can also tolerate 16 bar(g) pressure whereas the water side can handle up to 10 bar(g).

In addition, an accumulator (ASTM A516 grade 70), end suction pump, 2-4 poles and 380V/3ph/50Hz are included in the package. Thus, ITC offers you a high quality Package Plate Heat exchanger. It is, undisputedly, one of the best heat exchanger ever.

I.T.C. (1993) CO., LTD.

10, 12 ซอยรามคำแหง 118 แยก 61 แขวงสะพานสูง เขตสะพานสูง กทม. 10240
10, 12 Soi Ramkhamhaeng 118 Yak 61, Saphansoong, Saphansoong, Bangkok 10240 Thailand.

Tel : +66-2184-0055 Fax : +66-2184-0065

www.itc-group.co.th info@itc-group.co.th



Package

Plate Heat Exchanger By

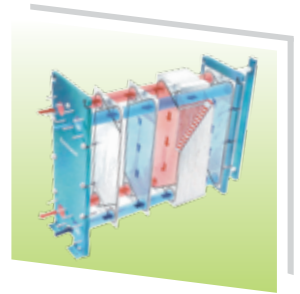

Furthermore, the plate sheets are composed of a solid stainless steel derived from plate SS304 material which has a high tensile strength that can last longer even more.

Besides, the maximum working pressure of the refrigerant side can tolerate a 16 bar(g) pressure whereas the water side can handle a maximum of 10 bar(g).

Others, an accumulator (ASTM A516 grade 70), end suction pump, 2-4 poles and 380V/3ph/50Hz are included in the package.

Thus, ITC offers you a high quality Package Plate Heat Exchanger you'll ever have.

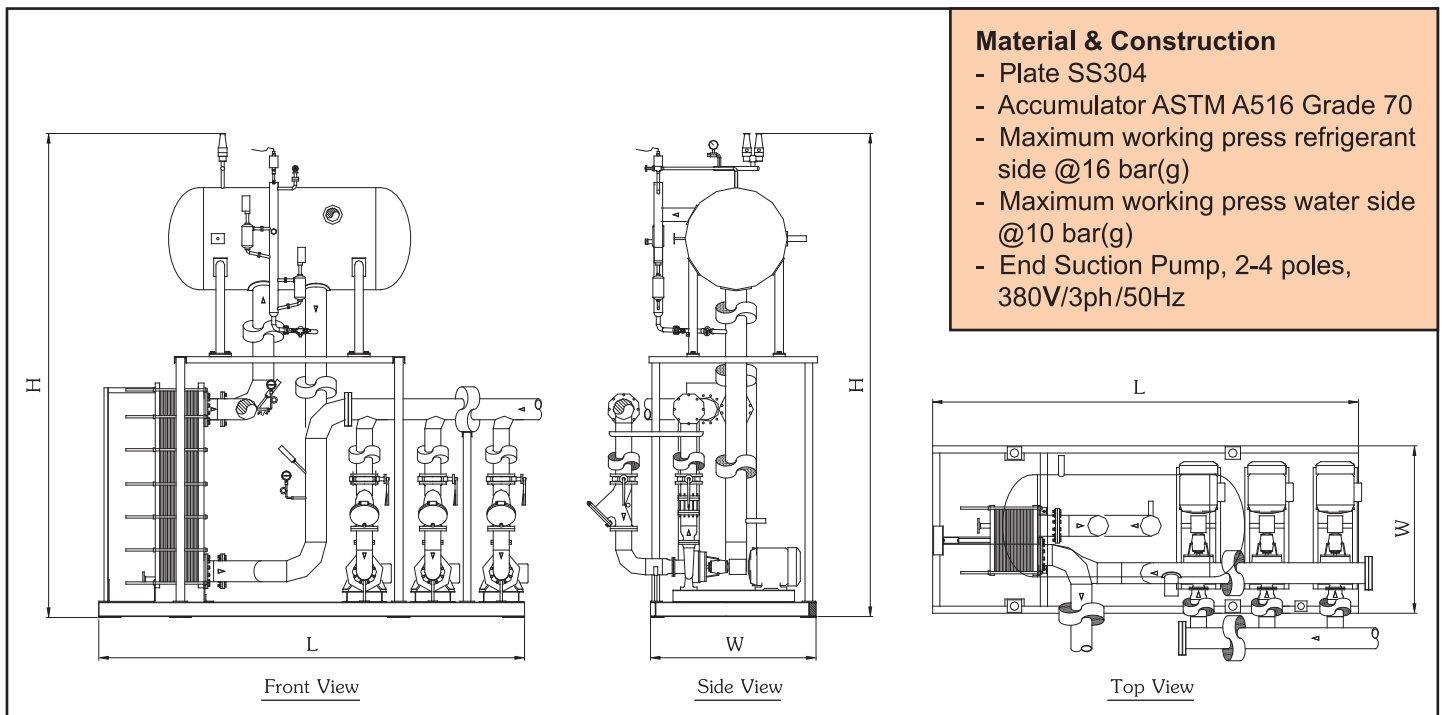

Standard Model Plate in Frame Glycol Chiller Package Specification

Design Condition

Hot side Media 25% Polypropylene, Inlet temp. +3 °C, Outlet temp. -2 °C
 Cold side Media Flooded Ammonia Evaporating temp. -5 °C

Model	Cooling Capacity		Glycol Data			Connection			Pump Motor @ kW	Package Dimension			
			Flow rate		Press. Drop bar	Suc. mm	Liq. mm	Glycol in/out mm		L mm	W mm	H mm	Weight kg
	kW	TR	m ³ /hr	gpm									
PLGC-26	90	26	16	70	0.35	50	15	65/40	5.5	2,600	1,100	2,820	663
PLGC-40	142	40	25	111	0.54	50	20	80/80	7.5	3,500	1,100	3,800	1,186
PLGC-73	257	73	46	201	0.55	80	25	80/80	11	3,540	1,230	3,910	1,527
PLGC-113	397	113	70	310	0.35	100	32	100/100	15	3,540	1,230	4,050	2,001
PLGC-178	627	178	111	490	0.39	100	32	125/100	22	4,820	1,370	4,210	2,763
PLGC-256	900	256	160	703	0.37	125	40	200/200	30	5,160	1,540	4,370	4,505
PLGC-348	1,222	348	217	954	0.38	125	50	200/200	45	5,420	1,540	4,530	5,321
PLGC-455	1,600	455	284	1,249	0.39	150	50	200/200	56	6,000	1,760	4,870	6,426
PLGC-597	2,100	597	372	1,640	0.40	150	65	200/200	75	6,920	1,980	5,040	8,000

Note : 1.) Other capacity and dimension are available, please contact manufacturer.
 2.) Specifications subject to change without notice.