

Glycol

Unit Cooler By **itc**

**Stainless Steel
Fan Blade and Guard**



Stainless Steel Casing and Fan Blade

I.T.C. (1993) CO., LTD.

10, 12 ซอยรามคำแหง 118 แยก 61 แขวงสะพานสูง เขตสะพานสูง กทม. 10240
10, 12 Soi Ramkhamhaeng 118 Yak 61, Saphansong, Saphansong, Bangkok 10240 Thailand.

Tel : +66-2184-0055 Fax : +66-2184-0065

www.itc-group.co.th

info@itc-group.co.th





Specifications

MODEL	fin pitch mm	Qo kW	Air Vol m ³ /h	Air Throw m	No. of fan	Fan Motor @w	PPG flow m ³ /h	P Drop bar	Dimension				Weight kg
									L mm	W mm	H mm	E mm	
150-IDG-241	4	13.1	5,200	8	1	400	2.4	0.4	1465	1296	844	1000	97
250-IDG-241	4	26.1	10,400	8	2	400	4.8	0.3	2465	1296	844	2000	168
350-IDG-241	4	49.4	15,600	8	3	400	9.0	0.7	3465	1296	844	1000	430
150-IDG-341	4	24.1	5,000	8	1	400	4.4	0.5	1465	1396	844	1000	107
250-IDG-341	4	46.3	10,000	8	2	400	8.4	0.4	2465	1396	844	2000	184
350-IDG-341	4	80.4	15,000	8	3	400	14.6	0.7	3465	1396	844	1000	475
150-IDG-271	7	7.4	5,200	8	1	400	1.4	0.1	1465	1296	844	1000	87
250-IDG-271	7	19.8	10,640	8	2	400	3.6	10.	2465	1296	844	2000	151
350-IDG-271	7	31.9	15,600	8	3	400	6.3	0.6	3465	1296	844	1000	387
150-IDG-371	7	15.5	5,200	8	1	400	2.9	0.6	1465	1396	844	1000	95
250-IDG-371	7	36.7	10,400	8	2	400	6.7	0.8	2465	1396	844	2000	166
350-IDG-371	7	54.7	15,600	8	3	400	10.0	0.8	3465	1396	844	1000	425

Single Discharge Draw thru Fan; Copper Tube/Coated Aluminum Fin
 Room temp = 10°C; 70%RH; PPG 27% -3/+2°C;

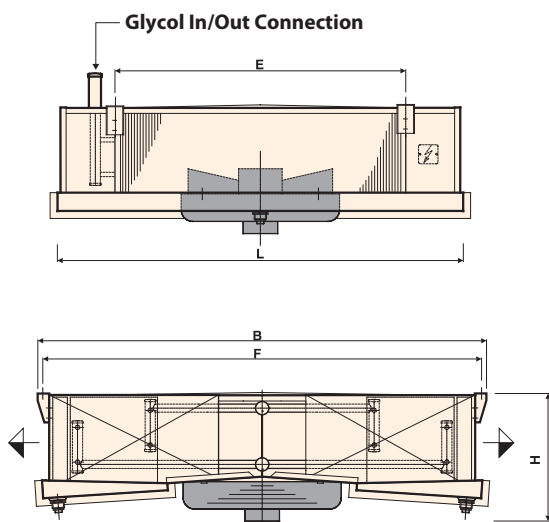

Standard Specification

- Copper Tube / Coated Aluminum Fin
- Tube arrangement Square 50 x 50 mm
- Casing Stainless Steel 304
- Double Tray with Insulation
- **Stainless Steel Fan Blade**
- **Aluminum Housing Fan Motor**
- Motor speed 1300 rpm
- Power 380V/3ph/50hz
- Ceiling Mount
- Air Defrost

Option

- Electric Defrost
- Droplet Separator
- Long Air Throw Nozzle
- Connection for Air Sock
- Hinged Drip Tray
- Hinged Fan Plate

